



EN50131-1 Grade 2
Environmental Class 2



FLEX

ACTIVE INFRARED BARRIER WITH ADJUSTABLE OPTICAL

INSTALLATION HANDBOOK
Ver. 1.2

1. INTRODUCTION

Active IR motion sensor FLEX are used to protect gangways and/or indoor and outdoor windows in protected positions with several heights and widths. They are made of 2 parts, transmitter and receiver, that have to be installed one opposite to the other. The main feature of this model is the ability to vary the position of the optics within the RX and TX aluminum bar. This solution also allows to modify the height of the same aluminum profile, adapted to every type of installation.

2. MAIN FEATURES

- Transmitter and receiver controlled by 2 microprocessors.
- Transmission of 5 bit codes every 20-50 ms to avoid masking with fake transmitters.
- Optical transmission modulation at 36 KHz and opaque polycarbonate filter to avoid disturbance by natural or artificial light.
- Optical synchronization between transmitter and receiver without additional connections.
- Control of oblique rays to avoid false alarms due to insects or small objects placed between tx and rx.
- Creep zone selectable and adjustable.
- Anti-opening and magnetic anti-removal selectable.
- Alarm output by means of a solid state relay.
- LED indication of the reception quality.
- Buzzer selectable.
- All settings are selectable using dip-switches.

3. TECHNICAL FEATURES

MODEL:	FLEX 500 - 2000
Numbers of rays:	from 2 to 8
Max Current (mA)	from 47 to 68
Power Supply (Vdc)	11 - 14
Length (mm)	da 505 a 2005
Height x Width (mm)	19x30
Certified temperature range	-5°C a +55°C
Operative temperature range	-30°C a +55°C
Colors:	White Brown Aluminium
Creep zone	✓
Anti-opening	✓
Anti-removal	✓
Range in normal conditions (min/max)	from 0,5m to 15m.
Range when exposed to the sun	from 0,5m to 6/12m
Alarm relay	1
Tamper relay	2
IP Protection Grade	IP55

4. INSTALLATION

The 2 elements, transmitter and receiver must be installed vertically one opposite to the other with the terminals oriented to the same direction.

Remove the cap, let the PCB slide fix the support cap to the wall. To access the DIP-SWITCHES and the Clamps it's just necessary to remove to upper caps.

Do not cover or paint the plastic housing of the items. Avoid the direct contact with rain or water jets.

Avoid, if possible, that the sunbeams reach directly the receiver, this could hinder the synchronization.

If the normal security precautions should not be enough, it is possible to use the anti-removal device: for the installation it is necessary to fix the magnet in the wall at the height of the magnetic contact (31,5 cm from the plug at the terminals side of the item). The contact connected to the circuit transmits the tamper signal if it is separate from the magnet in the wall. The system also has anti-opening tampers for the plugs..***. For the usage mount the apposite springs on the TAMPER microswitch (fig. 1 fig.2).

The system generates an alarm in case of power failure or any wire tearing.

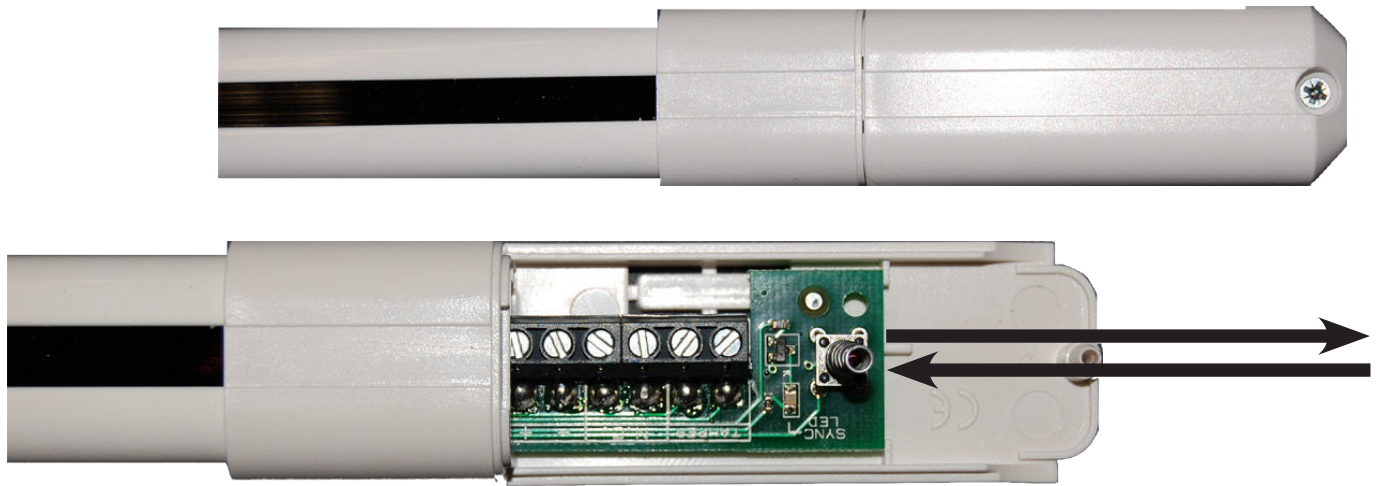

5. TRANSMITTER DIP-SWITCH CONFIGURATION - RANGE ADJUSTMENT

DIP - SWITCH 5 LINES (FIG2):	DIP 1	DIP 2	DIP 3	INDOOR	OUTDOOR	OUTDOOR WIHT SUN
DIP	off	off	off	0.5 ⇒ 6 m	0.5 ⇒ 2 m	0.5 ⇒ 2 m
	off	off	on	6 ⇒ 8 m	2 ⇒ 4 m	2 ⇒ 3 m
	off	on	on	8 ⇒ 12 m	4 ⇒ 6 m	3 ⇒ 6 m
	on	off	off	12 ⇒ 15 m	6 ⇒ 12 m	6 ⇒ 10 m
DIP 4	⇒ on antiremoval disabled			⇒ off antiremoval enabled		
DIP 5	⇒ on antiremoval and anti-opening disabled			⇒ off antiremoval and anti-opening enabled		

6. TRANSMITTER CONFIGURATION DIP-SWITCH: SETTING OF OPTICAL NUM.

DIP - SWITCH 3 LINES (FIG.2):

Attention: after the configuration of DIP, power OFF and then power ON the barriers to confirm the configuration

DIP 1	DIP 2	DIP 3	N° OTTICHE	DIP 1	DIP 2	DIP 3	N° OTTICHE
Off	Off	Off	2	On	Off	Off	6
Off	Off	On	3	On	Off	On	7
Off	On	Off	4	On	On	Off	8
Off	On	On	5	On	On	On	8

7. RECEIVER DIP-SWITCH CONFIGURATION:

DIP - SWITCH:	OFF	ON
1	Acoustic signalation (buzzer) disabled	Acoustic signalation (buzzer) enabled
2	Creep zone (terminals side) disabled	Creep zone (terminals side) enabled*
3	Creep zone (terminals opposite side) disabled*	Creep zone (terminals opposite side) enabled*
4	normal sensitivity	High sensitivity**
5	Anti-opening and anti-removal enabled	Anti-opening and anti-removal disabled disabilitati
6	Anti-removal enabled	Anti-removal disabled

* This function is used to allow small pets to pass through a protected window or door, when the alarm system is armed.

** This parameter reduces the reaction time of the Active IR beams, therefore it is suggested to use it with care and in places not directly exposed to sunbeams.

*** The plugs are not completely waterproof in order to avoid condensed water to stay inside and allow the beams to transpire.

8. SYNCHRONIZATION

As soon as the barriers are switched on they synchronize in a time between 1 and 10 seconds. If synchronization is OK the Buzzer (make sure that is enabled, dip1 receiver On) after some seconds becomes OFF. If it doesn't happen (buzzer already on) verify the setting of range and the proper mechanical alignment of the barriers. After the synchronization the led on the receiver flashes to indicate the quality of reception: see table.

TABELLA QUALITA' RICEZIONE		
<i>1 flash</i>	<i>bad reception</i>	<i>operation not optimal</i>
<i>2 flashes</i>	<i>good reception</i>	<i>sufficiently good operation</i>
<i>3 - 4 flashes</i>	<i>perfect reception</i>	<i>optimal operation</i>

9. FUNCTIONING

Every receiver checks the direct beam and the oblique ones (upper and lower), this ensures the protection against false alarms caused by small objects and bugs.

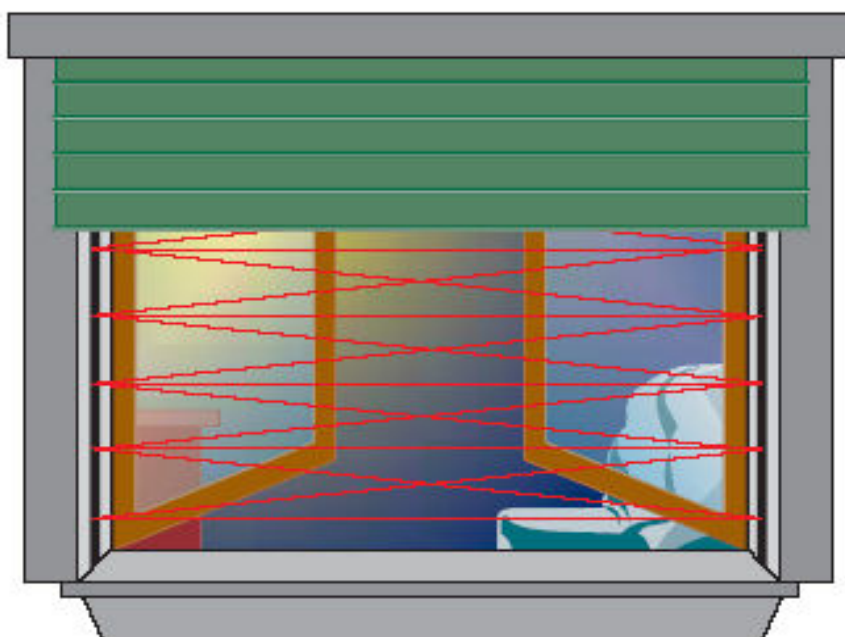

10. RISOLUZIONE DEI PROBLEMI

PROBLEM	CAUSE	SOLUTION
<i>led doesn't blink</i>	<i>difficult initialisation</i>	<i>check alignment</i>
		<i>verify presence of obstacles</i>
		<i>switch off and on again</i>
		<i>increase range and supply again</i>
<i>false alarms</i>	<i>difficult reception</i>	<i>verify alignment</i>
		<i>verify presence of obstacles</i>
		<i>increase range and supply again</i>
	<i>sun hitting the receiver</i>	<i>increase range and supply again</i>
		<i>if TX is not hitten by the sun, invert positions of TX and RX</i>
	<i>interference</i>	<i>avoid using remote controls or other devices using emitting infrared rays close to the RX</i>

11. CLAMPS

FIG.1

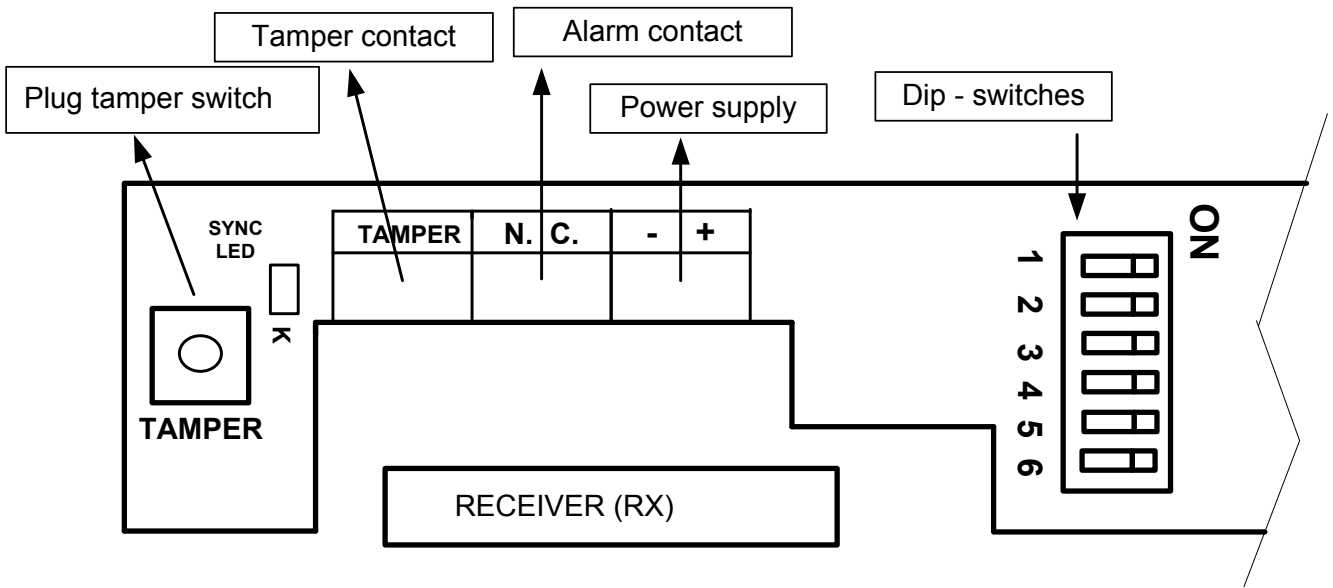
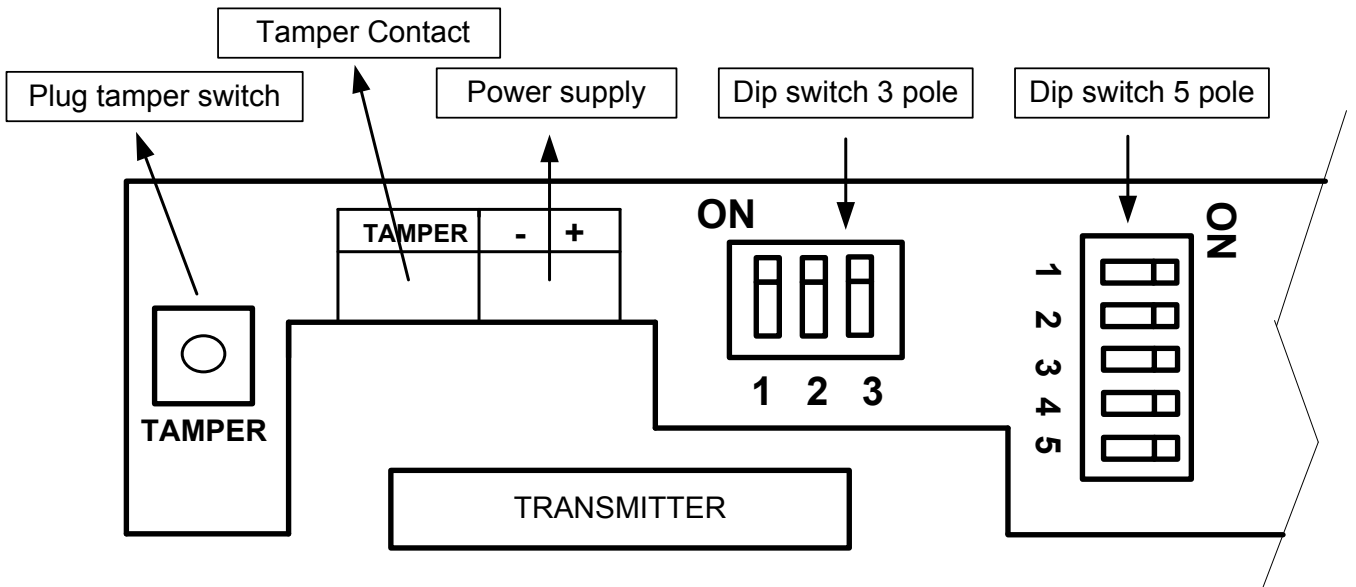

FIG.2



Our products/systems comply with the essential requirements of eec directives. installation must be carried out following the local installation norms by qualified personnel.

amc elettronica s.r.l. refuses any responsibility when changes or unauthorized repairs are made to the product/system.

it is recommended to test the operation of the alarm product/system at least once a month. despite frequent testing and due to, but not limited to, any or all of the following: tampering, electrical or communication disruption or improper use, it is possible for the product/system to fail to prevent burglary, robbery, fire or otherwise. a properly installed and maintained alarm system can only reduce the risk that this happens.